

# Marina picnic

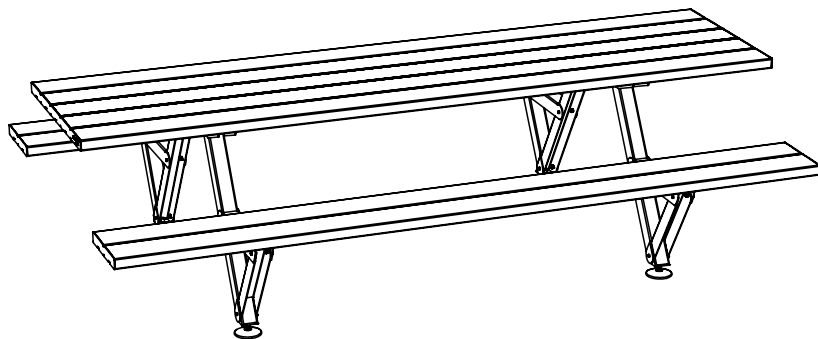

**extremis®**

**IMPORTANT! RETAIN FOR FUTURE  
REFERENCE: PLEASE READ ALL SAFETY  
NOTES AND INSTRUCTIONS. FAILURE  
TO COMPLY WITH THESE MAY RESULT  
IN SEVERE INJURIES.**

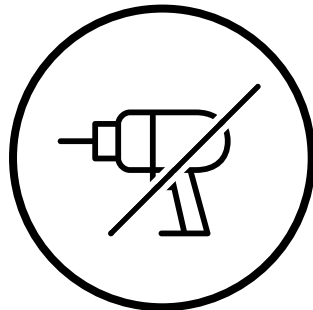

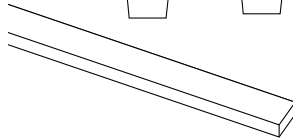
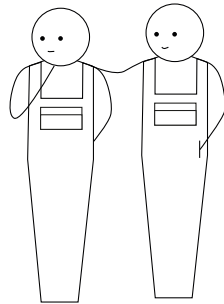
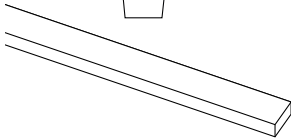
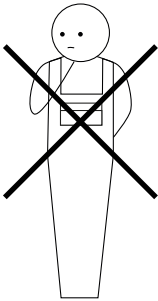
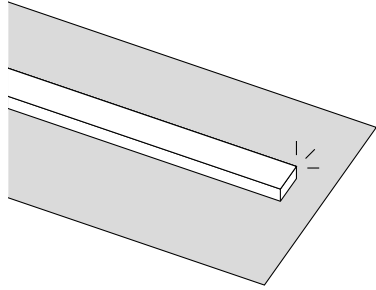
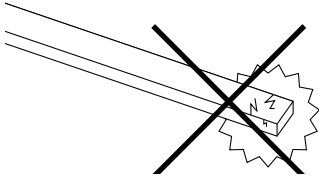

# Table of contents <sup>1/1</sup>

**Mounting kit <sup>↗</sup>**

---

**Assembly Marina picnic <sup>↗</sup>**

---

**Assembly floor fastening <sup>↗</sup>**

---

**Warnings - Text instructions -  
Maintenance <sup>↗</sup>**

**This is an interactive PDF**

You can easily navigate through this manual, allowing you to smoothly jump from one page to the other.

# Mounting kit



25 x M6

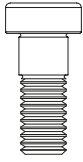

25 x M6x16

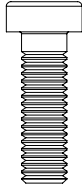

21 x M6x20

Mounting kit **MAR225** to fix  
the picnic leg



21 x M5x12

Mounting kit **MAR224**  
to fix the endcaps

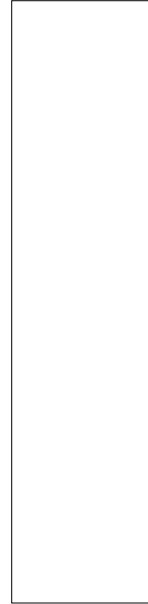

12 x spacer

Mounting kit **MAR208** spacers for  
the tabletop & benches



# Mounting kit

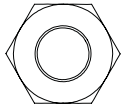

2 x M8

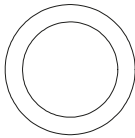

2 x spacer  
17,2x16

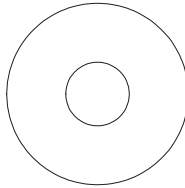

2 x 8,4

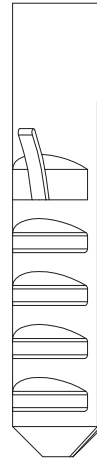

2 x plug  
12x60

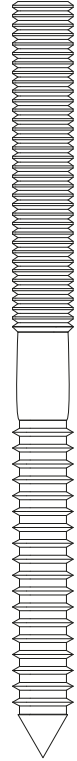

2 x stick screw  
M8x100

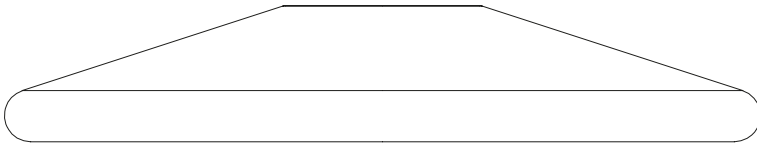

2 x footcap

Mounting kit **MAR121** to fix the floor fastening

# Marina picnic

1.

N° 10 - 17



N° 3 - 4



60'

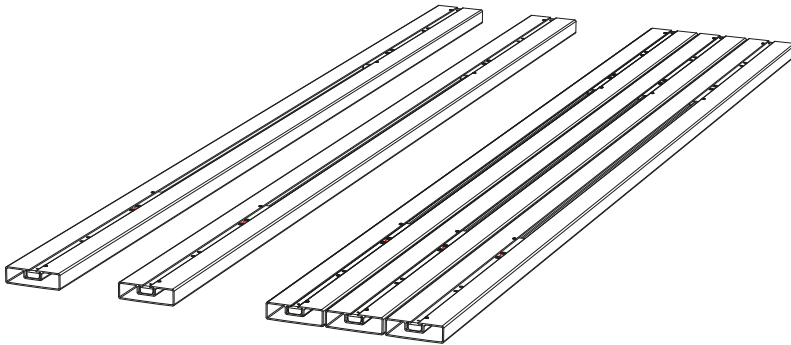

**Put the profiles on a protected surface**

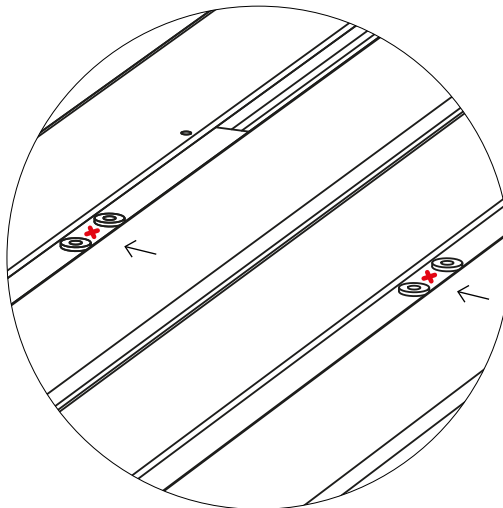

**If there are more than 2 legs, make sure the crosses on the bottom side of the profiles are facing the same side**

2.

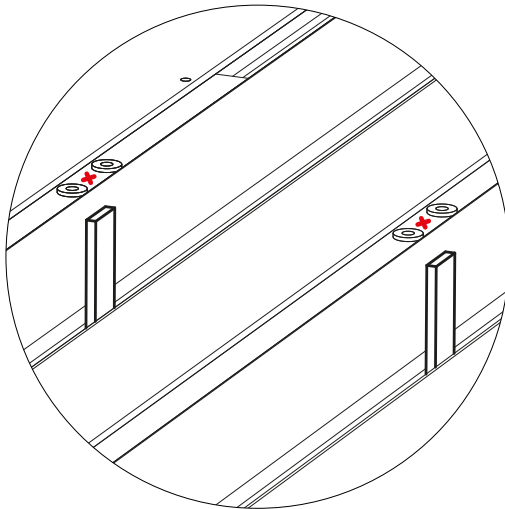
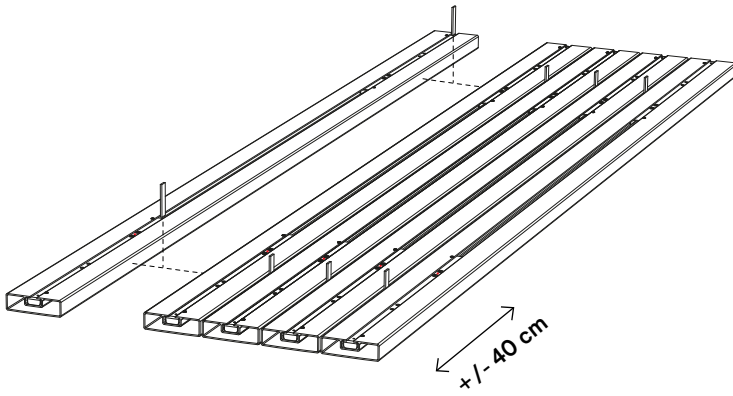

**MAR208**

**Insert a spacer plate between each profile at about 40 cm from the end**

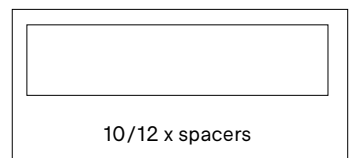



3.

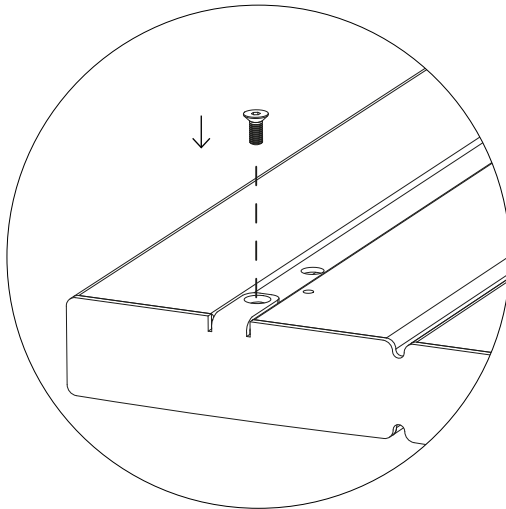
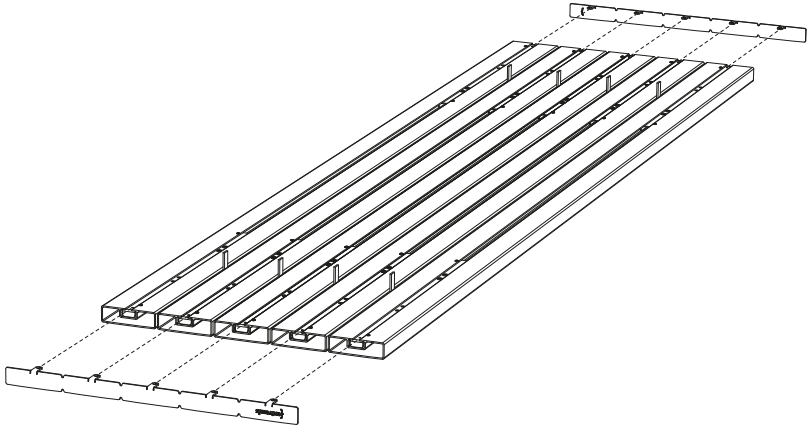

**Do this on both sides -  
Tighten all bolts!**

**MAR224**

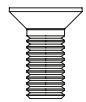

10/12 x M5x12

4.

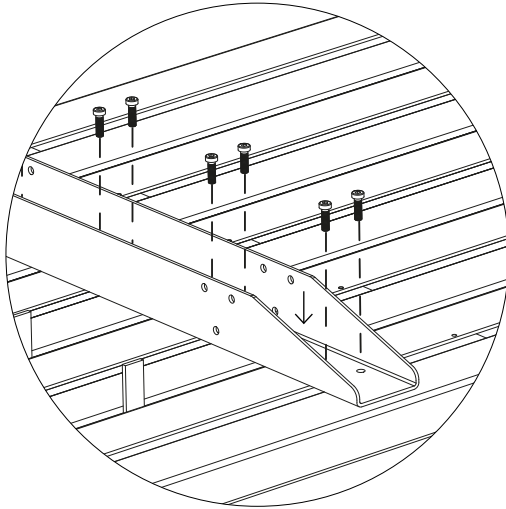
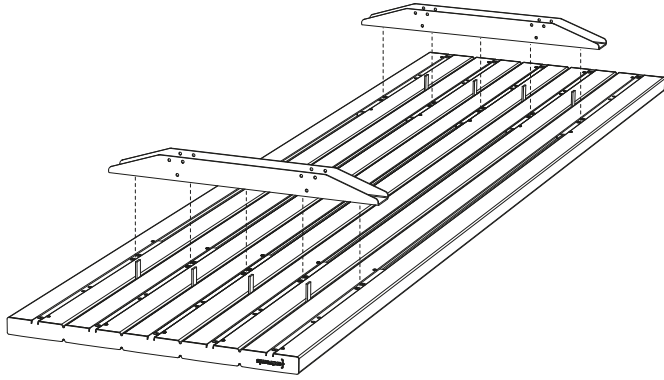

**Do this for all legs -  
Tighten all bolts!**

**MAR225**  
per leg

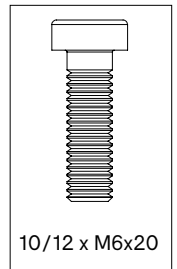

5.

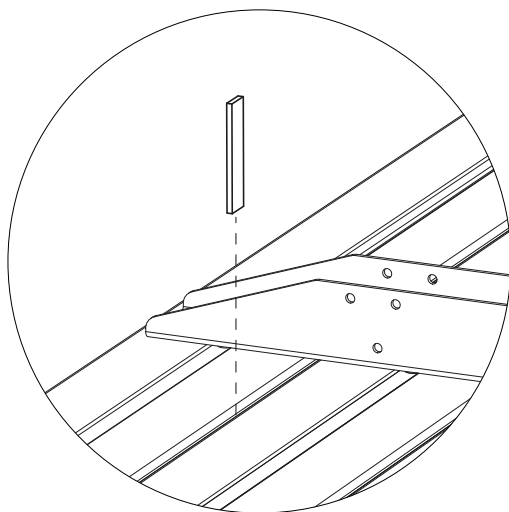

**Remove all spacers**

6a.

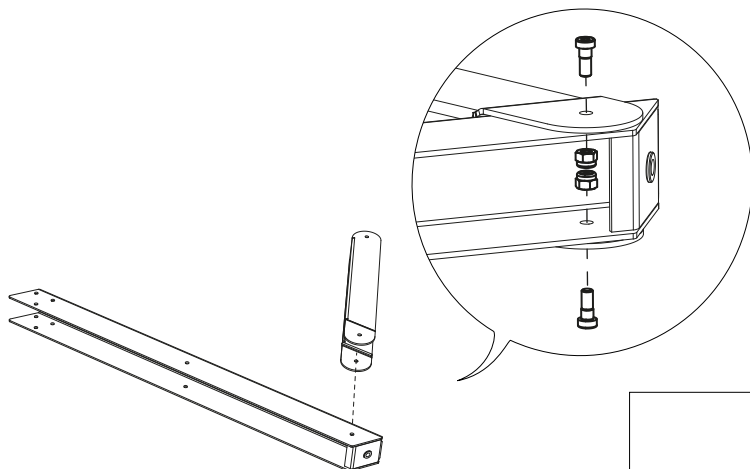

**MAR225**  
per leg

**Do not tighten!**

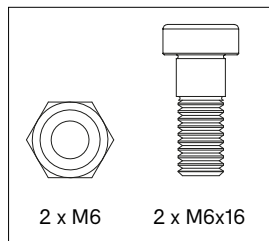

6b.

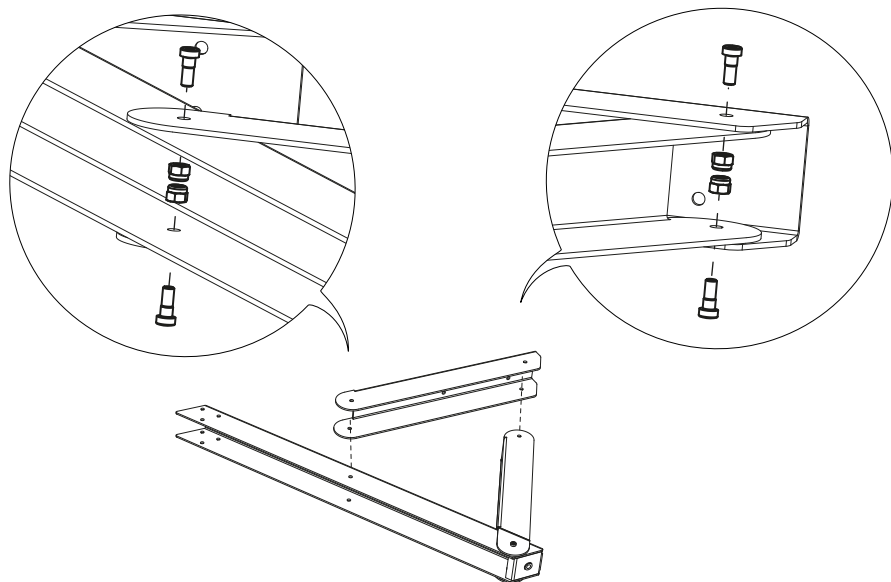

**MAR225**  
per leg

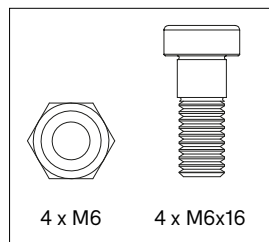

**Tighten all bolts!**

6c.

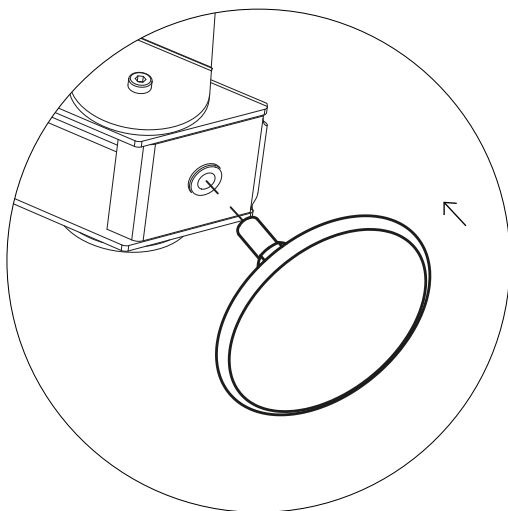
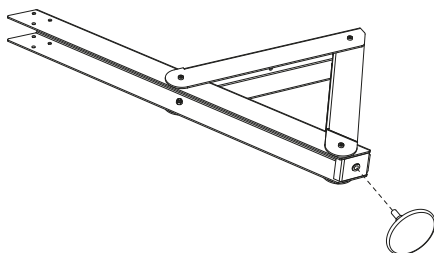

**Repeat steps 6a en 6c for the other side of the picnic leg**

7.

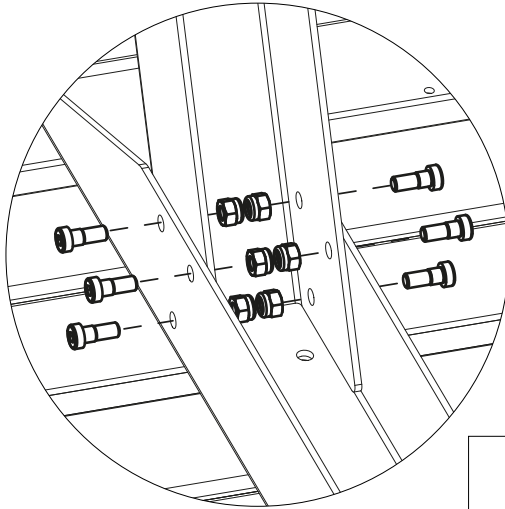
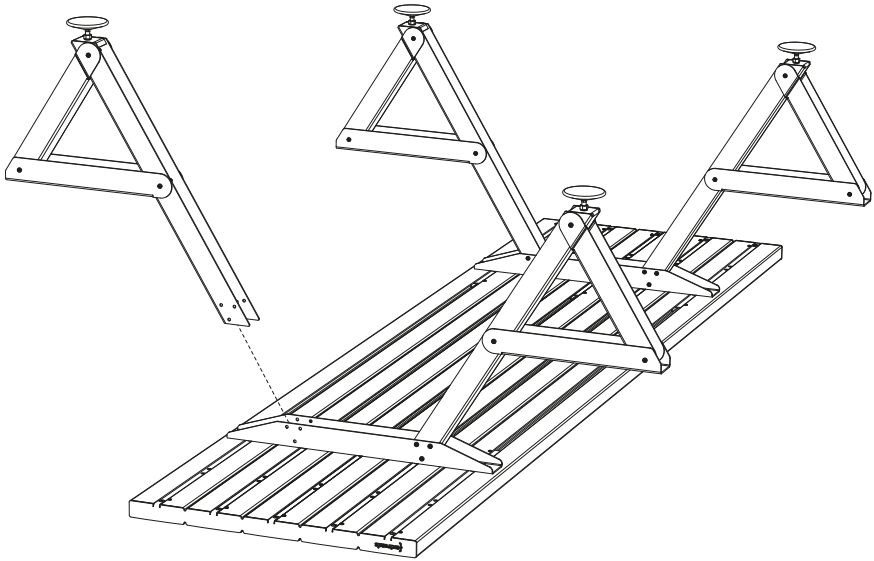

**MAR225**  
per leg

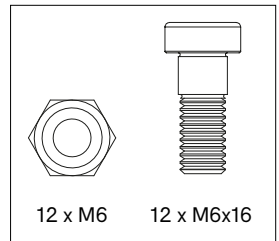

**Do this for all legs -  
Tighten all bolts!**

8.

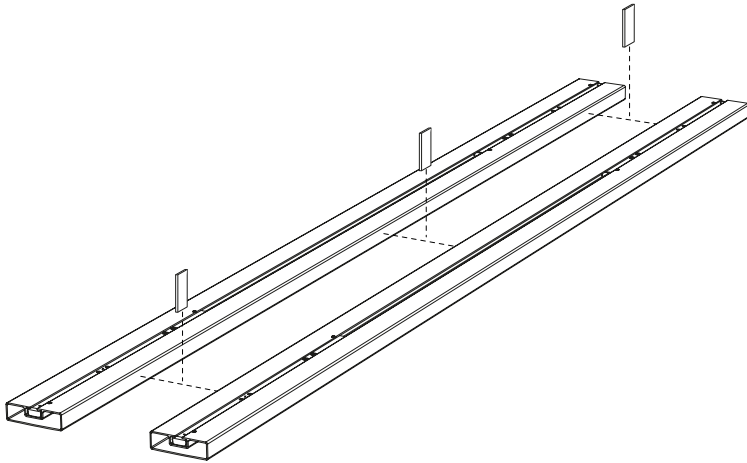

**Insert a spacer plate between each profile at about 40 cm from the end**

**MAR208**

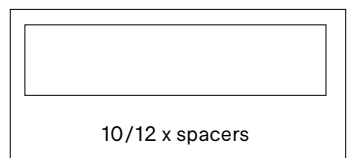

9.

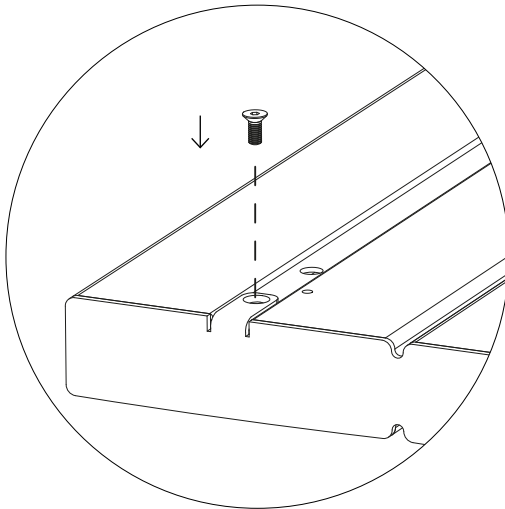
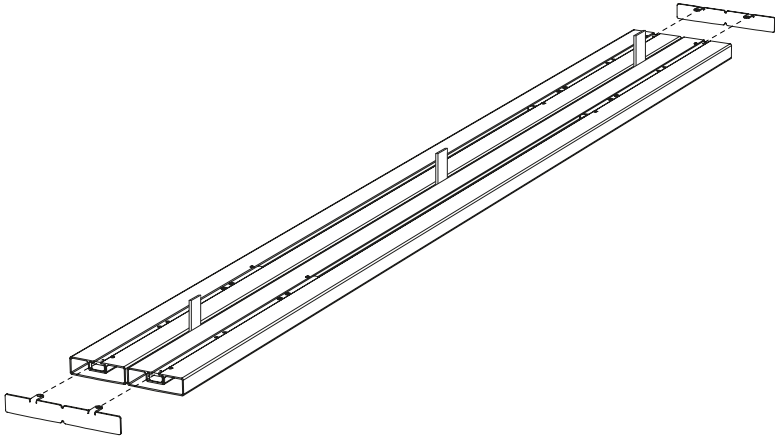

**Do this on both sides -  
Tighten all bolts!**

**MAR224**  
per bench

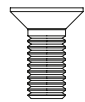

4 x M5x12



10.

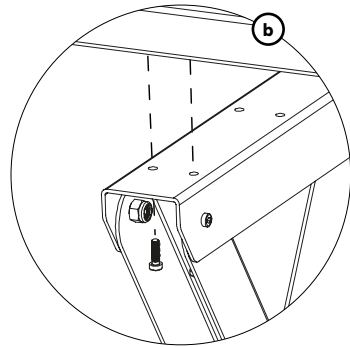
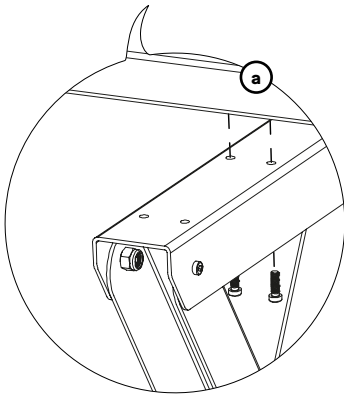
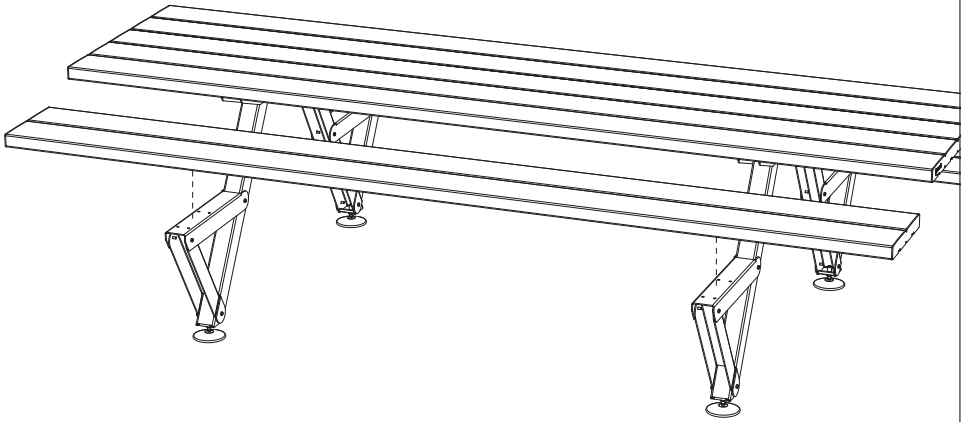

**MAR225**  
per bench

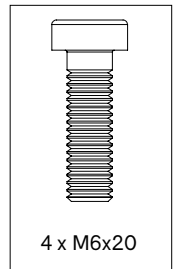

**First position the bolts on the inside of the table, then  
the bolts on the outside - Tighten all bolts!**

11.

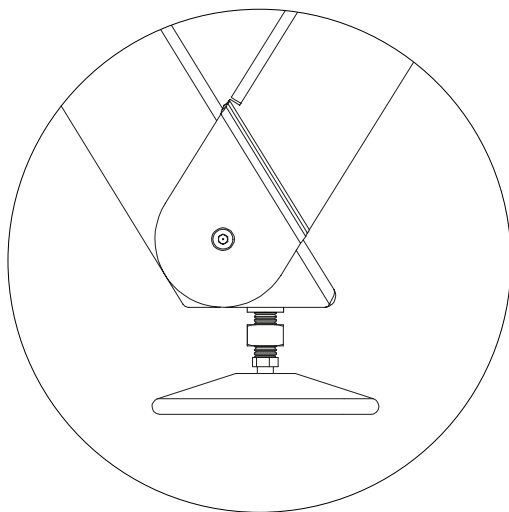

**Level the table by turning the leveling feet to  
greater or lesser extent**

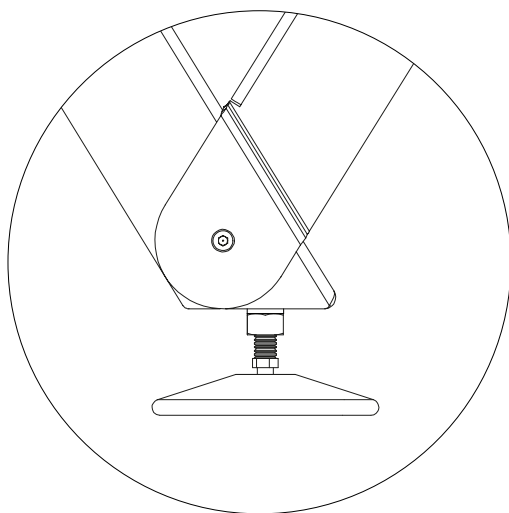

**Tighten the bolt!**

# Floor fastening

1.



30'

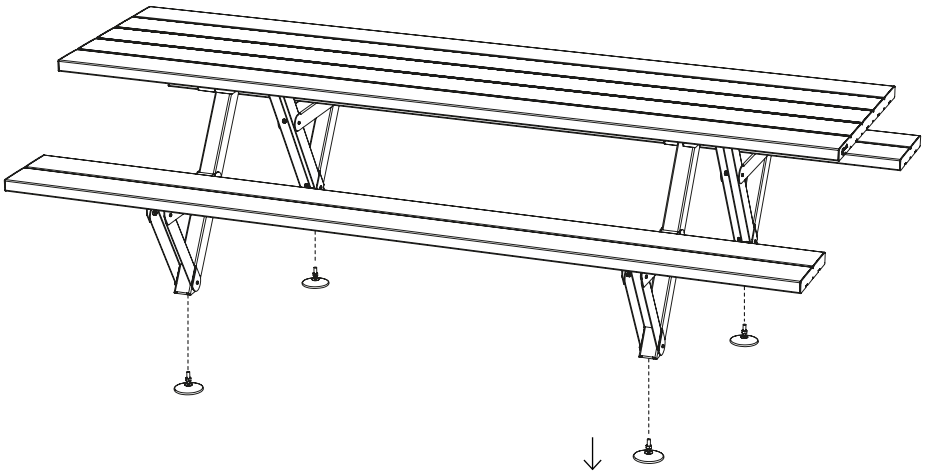

**Remove all feet**

2a.

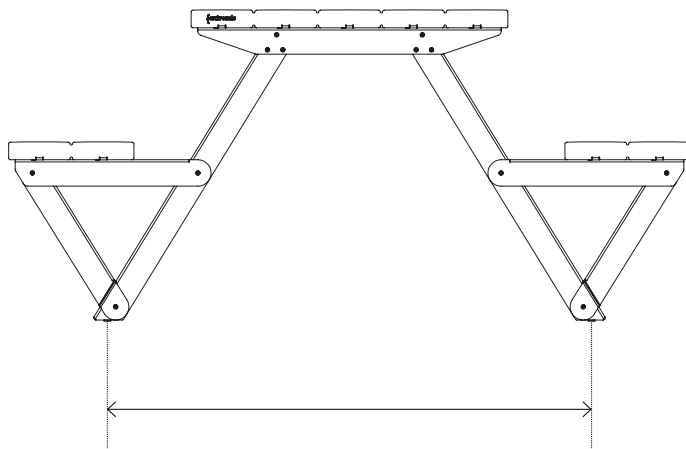

5 profiles = 110 cm

6 profiles = 125 cm

2b.

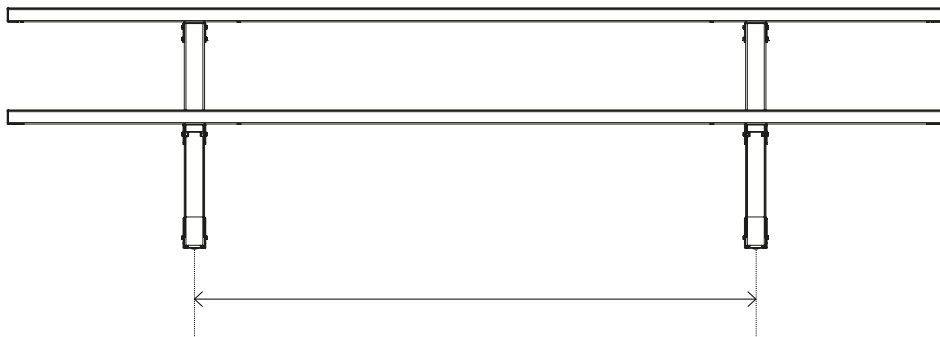

L = distance between center  
of the legs

3.

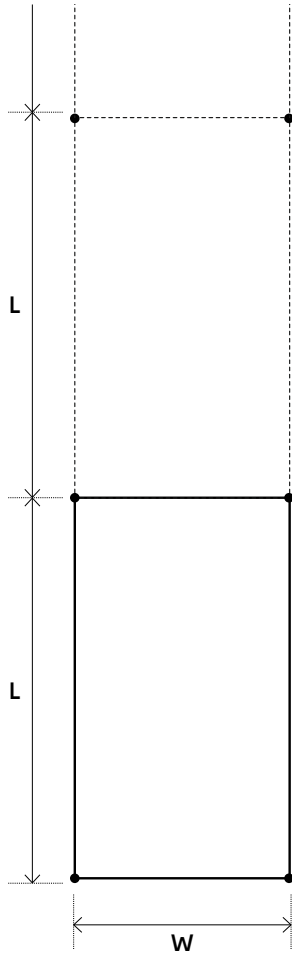

4.

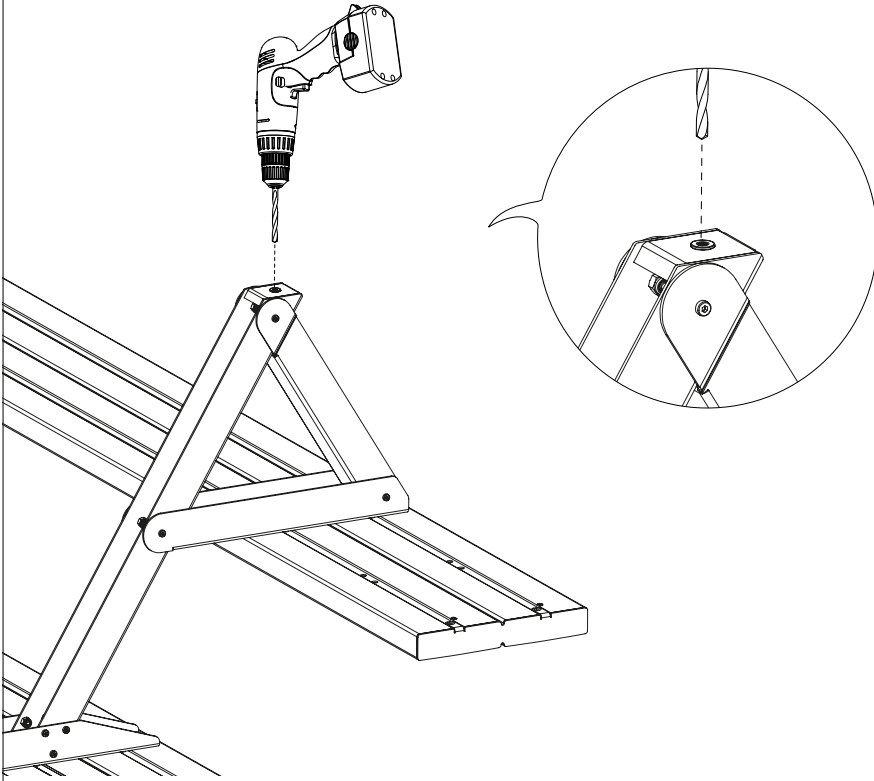

**If the ground anchoring kit was ordered later, there is a good chance that the tension nuts are still in the legs. Drill out the tension nuts using a  $\varnothing 12$  drill**

5.

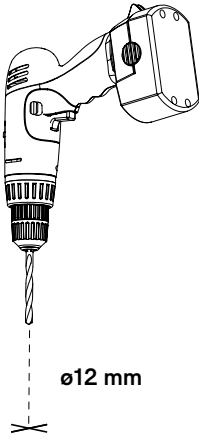

ø12 mm

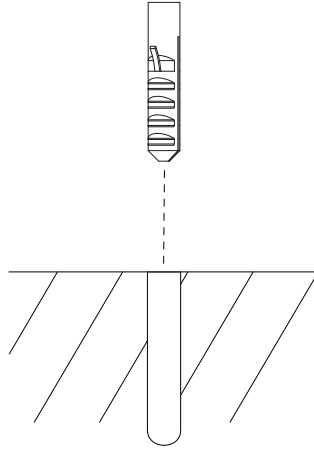

**MAR121**  
per leg

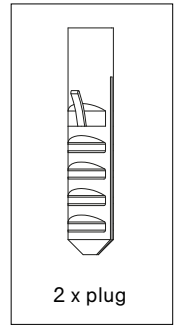

2 x plug

6.

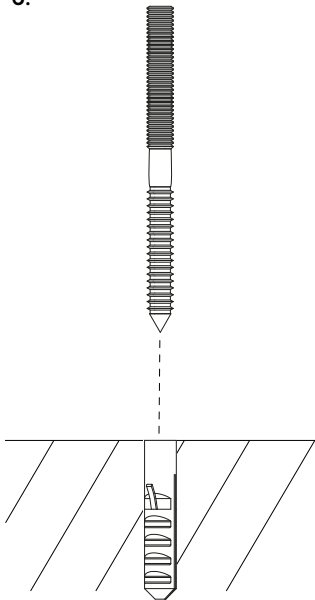

5,5 cm

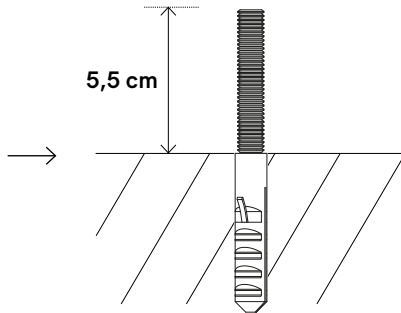

**MAR121**  
per leg

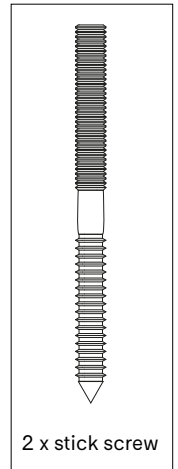

2 x stick screw

7.

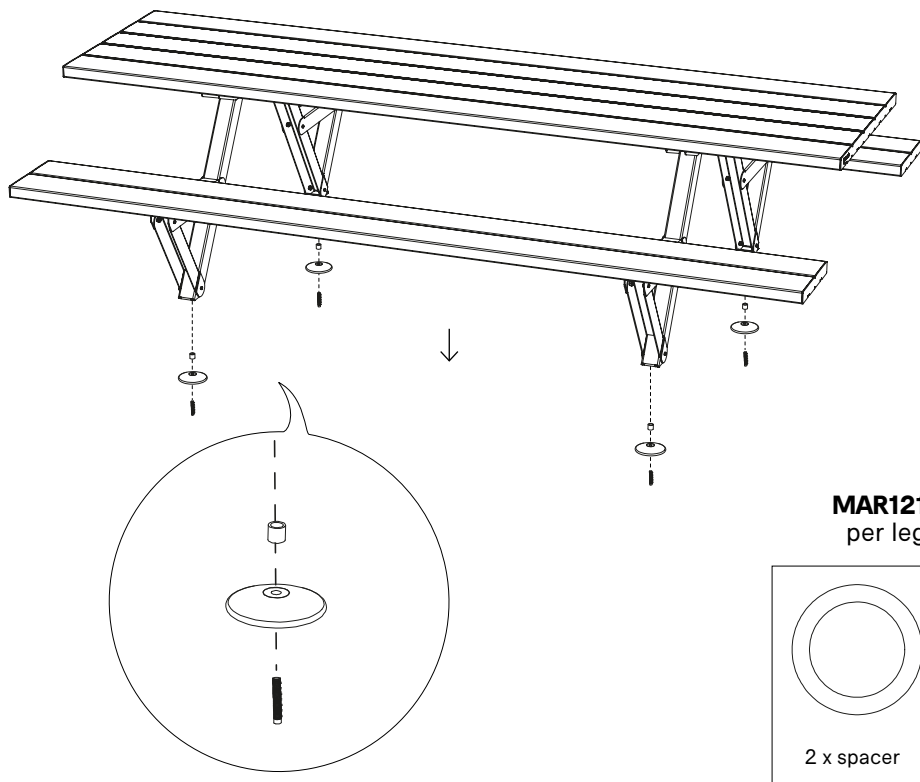

8.

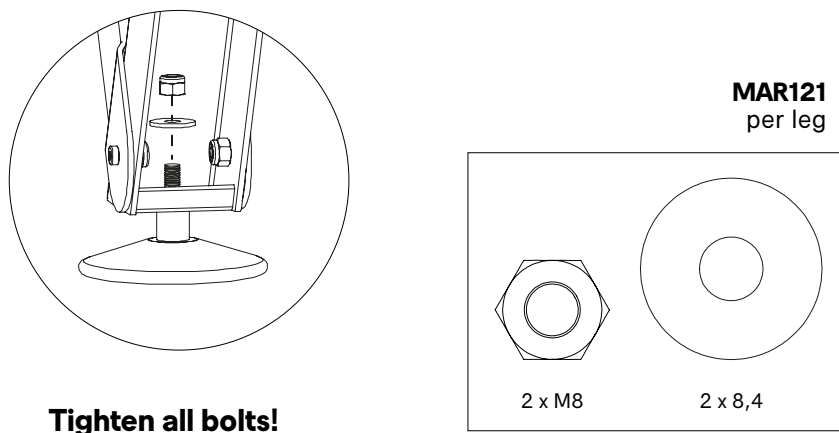



# **Warnings**

# **Text instructions**

# **Maintenance**

**Warnings** ↗

---

**Assembly text instructions** ↗

---

**Maintenance** ↗



# Warnings

## General

- Do not use any sharp tools to open the packaging.
- We strongly advise against using power tools.
- Tripping hazard, mind your step.
- Do not put out cigarettes on the bench.
- Not graffiti proof.
- Do not leave children unattended whilst playing on the bench.
- To avoid danger of suffocation, keep plastic bags away from babies and children.
- Colors can differ over years and from batch to batch.

## Product

- Do not drag the table, but carry it with minimum 2 people.
- Anchoring the product has to be done by qualified people.
- For anchoring: use suitable bolts or screws from a specialized store depending on the material your terrace is made of.
- We strongly advise you against standing on top of the table! A concentrated load can cause small perceptible cracks in the profiles that might be visually annoying, although they do not affect the strength of the table in any way.
- For table with 3 legs or more, we recommend using trestles to attach the table leg assemblies to the tabletop, instead of keeping it upside down.

## Powder coating

- White powder coating requires more maintenance.
- Do not use abrasive scouring powders or scourers as they will scratch the surface.
- Color can fade to some extent when exposed to UV.
- Flame retarding - NEN-EN13501-1 A2-s1 - Satisfying the same criteria



as Class B for the SBI-test according to EN13823. In addition, under conditions of a fully developed fire these products will not significantly contribute to the fire load and fire growth.

- Dark colors can get very hot in sunny weather.

## **Coated fiberglass**

- Do not use abrasive scouring powders or scourers as they will scratch the surface.
- Color can fade to some extent when exposed to UV.
- Dark colors can get very hot in sunny weather.

## **Sunbrella**

- Not waterproof, store inside!
- Shake or brush off loose dirt immediately.
- UV color fastness: 7/8 (ISO 105-B02).



# Assembly text instructions



Take a look at the drawings, starting from page 7

## Marina picnic (p7)

1. Place the 5 or 6 tabletop profiles on the floor with the slot openings facing up and use the packaging as protection. If there are more than 2 legs, make sure the crosses on the bottom side of the profiles are facing the same side.
2. Insert a spacer plate between each profile at about 40 cm from the end.
3. Insert the tabletop end pieces with the lips into the slots from left to right. Fasten them using 5 or 6 M5x12 countersunk bolts. Do this for both sides, the other side going from right to left. Attention: Max. 4,8 Nm.
4. Fix the tabletop connection profiles of the legs to the tabletop at the places provided using 10 or 12 M6x20 hex socket screws per leg. Attention: Max. 4,8 Nm.
5. Now remove the spacers.
6. **a.** Slide the bench supports onto the picnic leg and fasten them with the help of 2 M6x16 hex socket screws and 2 lock nuts M6. Attention: do not tighten the bolts yet.  
**b.** Slide the bench connections over the picnic leg and bench support and fasten them with 4 M6x16 hex socket screws and 4 M6 lock nuts. Now tighten all the bolts. Max. 8,8 Nm.  
**c.** Now screw the leveling feet into the legs. Repeat steps 6a to 6c for each leg set and them aside.



7. Slide the mounted picnic legs from step 6a to 6c into the tabletop connection. Align the holes and secure them with the help of 6 M6x16 hex socket screws and 6 M6 lock nuts per leg. Tip: first place all the bolts in the holes and make sure that the bolts are on the outside as shown in the drawing.
8. Place 2 bench profiles on the floor with the slot opening facing up and use the packaging as protection.
9. Insert the bench end pieces with the lips into the slots from left to right. Fasten them using 2 M5x12 countersunk bolts. Do this for both sides, the other side going from right to left and remove the spacers. Attention: Max. 4,8 Nm.
10. **a.** Place the benches on the leg assembly and first install 2 M6x20 bolts on the inside of the table, but do not fully tighten them yet.  
**b.** Now fasten the bolts (2 M6x20) on the outside of the table. Tighten all bolts. Attention: Max. 8,8 Nm.
11. Level the table by turning the leveling feet to greater or lesser extent and fasten them by tightening the nut against the leg.

## Floor fastening (p19)

1. Remove the existing leveling feet.
2. **a.** Width dimension: Tabletop with 5 profiles = 110 cm / Tabletop with 6 profiles = 125 cm.  
**b.** Length dimension, the distance between the center of the legs.
3. Mark where the table should be placed on the ground. You have 2 attachment points per leg; see the drawing. L = length between the centre of the legs / B = width between the centre of the legs.
4. If the ground anchoring kit was ordered later, there is a good chance that the tension nuts are still in the legs. Drill out the tension nuts using a  $\varnothing 12$  drill.
5. Drill  $\varnothing 12$  holes in the places marked & insert a 12x60 plug into each hole.
6. Then insert an M8x100 dowel screw into the plug until it protrudes by 55 mm.



7. Now place the feet and spacers on top of the pole ends and place the table on top.
8. Fasten them using the M8 plain washers & M8 nuts provided.



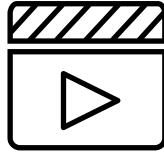

Watch the maintenance videos on our website:

[www.extremis.com/maintenance](http://www.extremis.com/maintenance)

## **Powder coating**

### **CLEANING**

#### Regularly

Use Extremis Multicleaner, a 100% biodegradable detergent or common kitchen cleaning products. Avoid using aggressive products. These surfaces are best cleaned with a neutral cleaning product diluted in water.

### **REPAIRING DAMAGED POWDER COATING**

#### When damaged

The impact of sharp objects can damage the coating. Scratches or dents can be touched up with our paint pens. However this only camouflages the scratches without removing them.

## **Coated fiberglass**

### **CLEANING**

#### When dirty, after use

Use Extremis Multicleaner, a 100% biodegradable detergent or common kitchen cleaning products. Avoid using aggressive products. These surfaces are best cleaned with a neutral cleaning product diluted in water.



## SPILLED LIQUIDS

### Immediately after use

It is best to treat spilt liquids immediately by placing a sheet of absorbent kitchen paper on them. The the earlier you clean them, the easier they're gone.

## Sunbrella

## SPILLED LIQUIDS

### Immediately after use

It is best to treat spilt liquids immediately by placing a sheet of absorbent kitchen paper on them. The water-resistant coating on the Sunbrella prevents droplets from penetrating the fabric.

## REGULAR CLEANING

### When dirty

Make a solution to remove stains on your Sunbrella.

## MACHINE WASHING

### Rarely

It is also possible to put the blankets and cushion covers in a washing machine (30°). Do not dry clean or tumble dry. The fabric can be creased. Ironing will help to recover the waterrepellent coating of the fabric, but only at a cool setting (delicates). As some irons exceed the recommended temperature at the synthetic setting, test a small, inconspicuous area before ironing the entire fabric. DO NOT use a steamer or iron set to the steam setting.

## REMOVING STUBBORN STAINS

### Only if nothing else helps

More drastic measures needed? Bleach can be used if nothing else helps. Protect the area around your Sunbrella fabric when using a bleach solution – bleach may discolour non-Sunbrella fabrics. Please be aware of the environment when cleaning with bleach. Bleach can have harmful





effects on the natural environment around you. We do not advise using bleach if you are surrounded by a body of water or another environment that could be affected. If stains and/or mildew marks are severe, the quantity of bleach may be increased.





Our headquarters:  
Couthoflaan 20b  
B-8972, Poperinge  
info@extremis.com  
+ 32 57 346020

**extremis.com**

Connect with us



All rights reserved. Unless otherwise specified, all designs and photographs contained in this publication are copyright protected and are the property of Extremis. No part of this publication may be copied or distributed without Extremis' prior written consent. The names of the authors of photographs to which we do not hold rights are mentioned here. We have done our utmost to provide a comprehensive list of names. In the event of an alleged breach, please contact the editorial staff. © Extremis

LAB020